

For protection of Electronic Telephone Systems, PBX's, KSU's and Key Systems .

FEATURES & BENEFITS

- UL 497 Listed for primary protection
- Utilizes industry standard 5-pin protector modules
- 110 IDC termination input and output
- High-impact, fire retardant housing
- Units can be cascaded to provide for expansion
- Compact, lightweight design
- AQL Incoming Inspection Process
- ISO 9001:2000 registered facility
- Operating Temperature: -13°F to 149°F
(-25°C to 65°C)

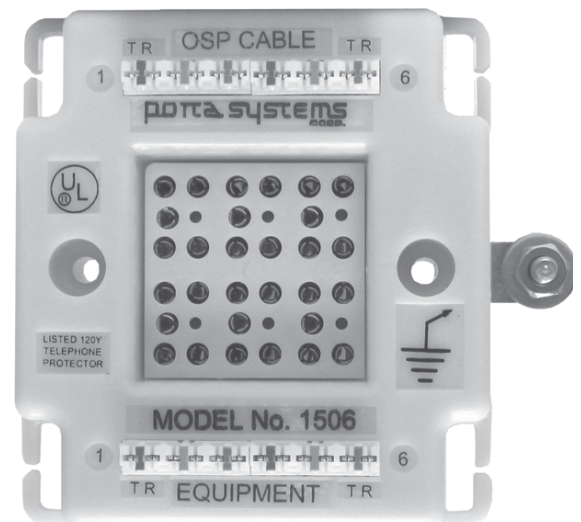

ORDERING INFORMATION

Model#	Pair Count	Input	Output	Modules	Module Model#
1506	6	110	110	None	NA
1506GT	6	110	110	230V Gas Tube	175BCXN-230
1506SS240	6	110	110	240V Solid State	115SCN-240
1506SS75	6	110	110	75V Solid State	115SCN-75
1506D230	6	110	110	230V Delta	195BCDXN-230
1506D75	6	110	110	75V Delta	195BCDXN-75

BUILDING ENTRANCE PROTECTOR



110 Termination

MECHANICAL SPECIFICATIONS FOR 1506 BUILDING ENTRANCE PROTECTOR:

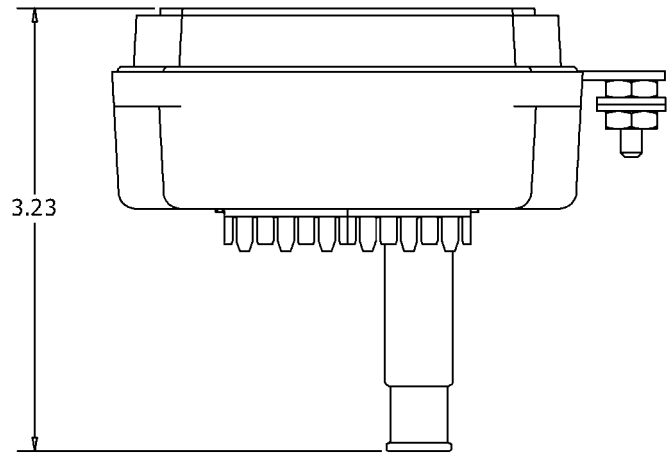
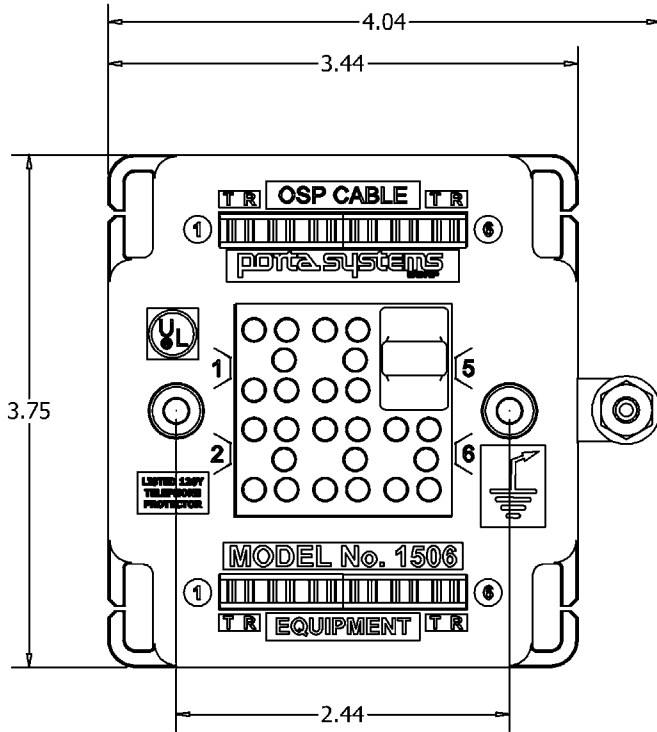

Pair Count	Dimensions (height x width x depth)	Weight (approx.)*
6 PAIR	3.75" x 4" x 3.3" (9.5 cm x 10 cm x 8.2 cm)	2 lbs.

* Weight - Add approx 0.5 oz per installed module.



For more information contact:
 6851 Jericho Turnpike, Suite 170
 Syosset, NY 11791 USA
 Tel. 1-516-364-9300 : Fx. 1.516.682.4636
 sales@portasystems.com (Americas)
 sales@portasystems.co.uk (Europe)